

## ● SCM-1000 VACUUM DEGASSER

The Scomi Oiltools SCM-1000 vacuum degasser is a rugged vacuum unit that is designed to safely and efficiently remove 99.9% of entrained air and gases such as methane, H<sub>2</sub>S and CO<sub>2</sub> from drilling fluid.

### FEATURES & BENEFITS

- 5 hp (3.73 kW) TEXP electric motor with starter and fan guard (Available in ATEX/EU)
- Processing capacity of 1000 gpm (3785 lpm) with up to 16 ppg (1.92 sg) drilling fluid
- Up to 29" Hg performance for viscous fluids
- 15,981 in<sup>2</sup> ( 10.3 m<sup>2</sup>) of baffle surface area
- Epoxy coated internal surfaces for corrosion resistance
- Fail-safe overflow valve
- Low maintenance float assembly
- Easy access to baffles and float switch
- Compact design for easy installation
- Skid-mounted unit
- Minimal moving parts for reliable operation

The vacuum degasser consists of a 5 hp (3.73 kW) TEXP motor rated for continuous operation running an Ingersoll-Rand vacuum pump with a push-button starter panel. The self-contained unit provides up to 29" of Hg of vacuum to efficiently handle high-viscosity fluids.

The SCM-1000 vacuum degasser operates on the 'thin strata principle' in which a thin layer of drilling fluid is forced over seven baffle plates arranged to maximise surface area and vacuum exposure. Vacuum is applied to the drilling fluid as it flows across the baffles. These forces combine to 'break out' 99.9% of entrained gasses. Degassed mud is passed on to downstream handling equipment while waste gas is routed from the rig to be flared or captured by environmental control equipment.



**SPECIFICATIONS**

Capacity	1000 gpm (3785 lpm)
Leaf Area	15,981 in <sup>2</sup> ( 10.3 m <sup>2</sup> )
Vacuum	up to 29" of Hg
<b>Dimensions</b>	
101" x 68" x 79" (2565 mm x 1727 mm x 2006 mm)	
<b>Weight</b>	
4000 lb (1814 kg)	

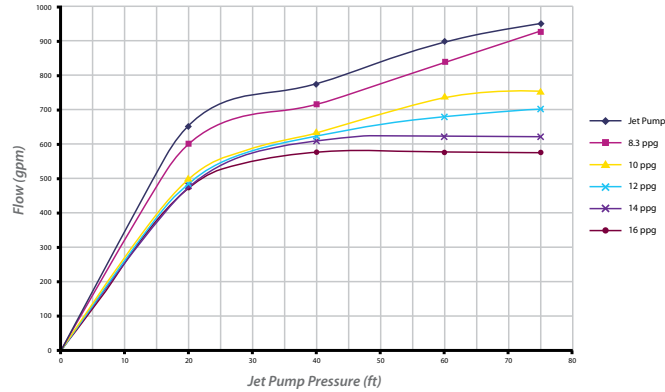

Clean, properly formulated drilling fluids increase the efficiency of drilling operations, reducing down time and extending equipment life.

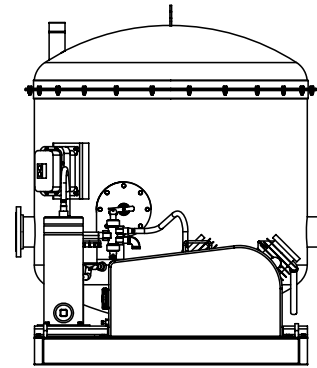
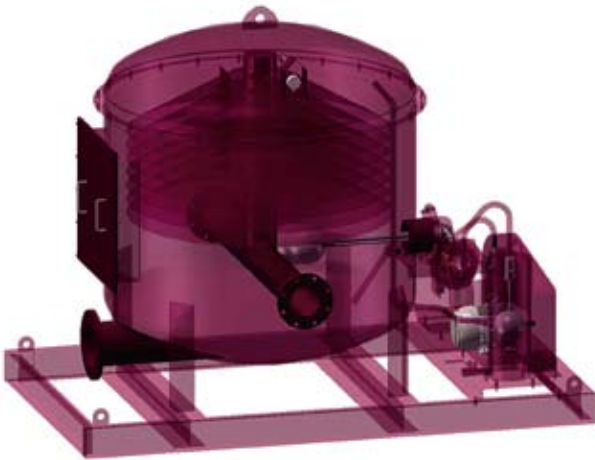

END VIEW

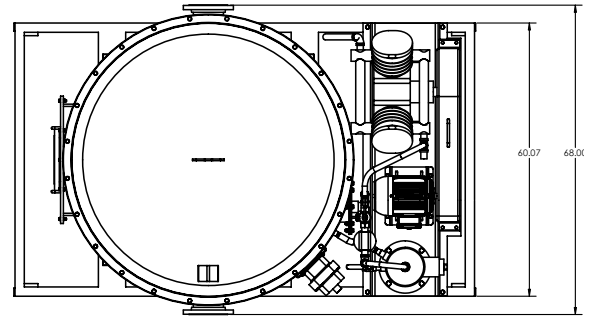

PLAN VIEW

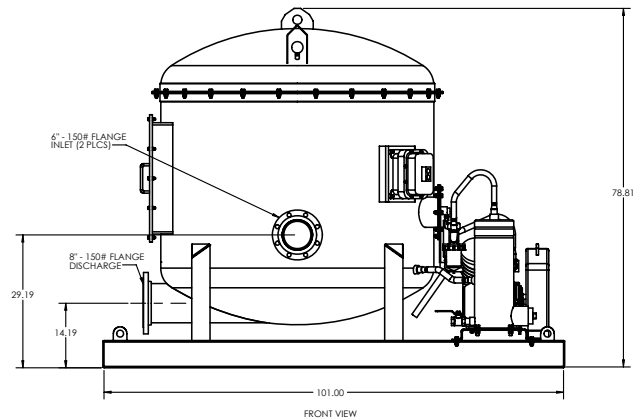

www.scomioiltools.com.my

<b>Europe</b>	T +44 1224 719 200	F +44 1224 708 677
<b>Middle East</b>	T +9714 8838 236	F +9714 8838 920
<b>Americas</b>	T +1281 260 6016	F +1281 260 6969
<b>Asia</b>	T +603 2080 5080	F +603 2080 5083
<b>West Africa</b>	T +234 803 402 8010	F +1832 550 2582

E aberdeen.sales@uk.scomioiltools.com
E dubai.sales@ae.scomioiltools.com
E houston.sales@us.scomioiltools.com
E kl.sales@my.scomioiltools.com
E nigeria.sales@my.scomioiltools.com

Terms & conditions apply. Please refer to www.scomigroup.com.my/t&c for further information. Copyright © 2010 Scomi Oiltools Bermuda Limited. All Rights Reserved.

Printed on environmentally friendly paper • FSDSND-Rev0810